



Venus638FLPx 65 Channel Low-Power GPS Receiver

FEATURES

- 20Hz update rate
- -148dBm cold start sensitivity
- -165dBm tracking sensitivity
- 29 second cold start TTFF
- 3.5 second TTFF with AGPS
- 1 second hot start
- 2.5m accuracy
- Multipath detection and suppression
- Jamming detection and mitigation
- SBAS (WAAS / EGNOS) support
- 7-day extended ephemeris AGPS
- 67mW full power navigation
- Works directly with active or passive antenna
- Internal flash for optional 75K point data logging
- Supports external SPI flash memory data logging
- Complete receiver in 10mm x 10mm x 1.3mm size
- Contains LNA, SAW Filter, TCXO, RTC Xtal, LDO
- Requires only antenna and power to work
- Pb-free RoHS compliant

The Venus638FLPx is a high performance, low cost, single chip GPS receiver targeting mobile consumer and cellular handset applications. It offers very low power consumption, high sensitivity, and best in class signal acquisition and time-to-first-fix performance.

Venus638FLPx contains all the necessary components of a complete GPS receiver, includes GPS RF front-end, GPS baseband signal processor, 0.5ppm TCXO, 32.768kHz RTC crystal, RTC LDO regulator, and passive components. It takes up only 100mm² PCB footprint.

Dedicated massive-correlator signal parameter search engine within the baseband enables rapid search of all the available satellites and acquisition of very weak signal. An advanced track engine allows weak signal tracking and positioning in harsh environments such as urban canyons and under deep foliage.

Venus638FLPx is very easy to use, minimizes RF layout design issues and offers very fast time to market.

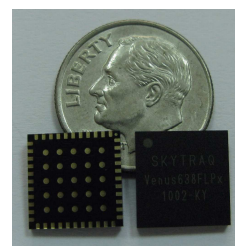

TECHNICAL SPECIFICATIONS

Receiver Type	L1 frequency GPS C/A code, SBAS capable 65-channel architecture 8-million time-freq search / sec
Accuracy	Position 2.5m CEP Velocity 0.1m/sec Time 60nsec
Open Sky TTFF	29 second cold start 3.5 second with AGPS 1 second hot start
Reacquisition	< 1s
Sensitivity	-165dBm tracking -148dBm cold start
AGPS	7-day extended ephemeris
Update Rate	1 / 2 / 4 / 5 / 8 / 10 / 20 Hz Default 1Hz
Dynamics	4G
Operational Limits	Altitude < 18,000m ^{*1} and Velocity < 515m/s ^{*1}
Serial Interface	LVTTTL level
Protocol	NMEA-0183 V3.01 SkyTraQ Binary
Power Consumption	67mW full power tracking 92mW low power acquisition 114mW max perf. acquisition
Package	LGA69 10 x 10 x1.3 mm
Compliance	RoHS
Weight	0.3g

*1: COCOM limit

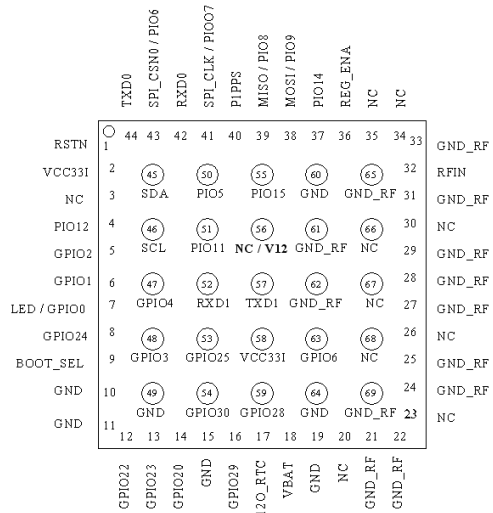

ORDERING INFORMATION

Part Number	Description
Venus638FLPx-D	Single Chip GPS Receiver, Flash type 1.2V + 3.3V Dual Supply
Venus638FLPx-L	Single Chip GPS Receiver, Flash type 3.3V Single Supply

SkyTraQ Technology, Inc.
4F, No.26, Minsiang Street, Hsinchu, Taiwan, 300
Phone: +886 3 5678650
Fax: +886 3 5678680
Email: info@skytraq.com.tw

© 2010 SkyTraQ Technology Inc. All rights reserved.
Not to be reproduced in whole or part for any purpose without written permission of SkyTraQ Technology Inc ("SkyTraQ"). Information provided by SkyTraQ is believed to be accurate and reliable. These materials are provided by SkyTraQ as a service to its customers and may be used for informational purposes only. SkyTraQ assumes no responsibility for errors or omissions in these materials, nor for its use. SkyTraQ reserves the right to change specification at any time without notice.

These materials are provided "as is" without warranty of any kind, either expressed or implied, relating to sale and/or use of SkyTraQ products including liability or warranties relating to fitness for a particular purpose, consequential or incidental damages, merchantability, or infringement of any patent, copyright or other intellectual property right. SkyTraQ further does not warrant the accuracy or completeness of the information, text, graphics or other items contained within these materials. SkyTraQ shall not be liable for any special, indirect, incidental, or consequential damages, including without limitation, lost revenues or lost profits, which may result from the use of these materials.

SkyTraQ products are not intended for use in medical, life-support devices, or applications involving potential risk of death, personal injury, or severe property damage in case of failure of the product

